

Integrating sensor measurements through CM cards as an OMF service ^{*}

Vasilis Maglogiannis, Dimitris Giatsios, Giannis Kazdaridis,
Thanasis Korakis, Iordanis Koutsopoulos, and Leandros Tassioulas

Department of Computer and Communication Engineering
University of Thessaly
Centre for Research & Technology Hellas (CERTH)
Volos, Greece {vomaglog, gidimitr, iokazdarid, korakis, jordan, leandros}@uth.gr

Abstract. Several OMF-based testbeds are using Chassis Manager (CM) cards for autonomously controlling and monitoring the status of nodes. CM cards are typically microcontroller boards and can be connected to different kinds of modules, including sensor modules. The NITOS testbed, which has recently adopted the use of CM cards, features various types of sensors connected to them. Measurements can be easily obtained through dedicated web services running on the microcontroller, through a network interface. This demo describes the implementation of an OMF service on top of these CM card measurement web services. This service can either be requested directly by an experimenter who wishes to obtain a specific sensor measurement, or it can be utilized in OMF experiment scripts.

1 Introduction

Chassis Manager (CM) cards have been introduced as an out-of-band management solution for experimental network testbeds, particularly for the purpose of remotely powering testbed nodes on or off. They are a relatively cost-efficient solution especially for wireless testbeds, where testbed nodes are typically distributed in a wide area rather than gathered in racks.

NITOS [1], a publicly available wireless testbed at the premises of University of Thessaly featuring almost 50 outdoor nodes, has recently adopted the use of CM cards. In particular, NITlab, the laboratory maintaining the NITOS testbed, developed a set of custom CM cards [2] for the nodes, based on AVR microcontrollers. The cards were supplied with several sensor modules, including temperature and humidity sensors as well as power meters. NITOS had already been featuring sensors among its equipment, connected to the nodes via USB, but the deassociation of sensor functionalities from the node itself offers several advantages, the most important being energy saving, as the node doesn't have to be powered on in order to get a sensor measurement. The microcontroller used for the NITOS CM cards features an Ethernet interface and a tiny webserver which allows programming of web services. Therefore, requesting a measurement from a sensor attached to the CM card can be easily done through a simple HTTP request to the webserver of the microcontroller.

^{*} The research leading to these results has received funding from the European Community's Seventh Framework Programme (FP7/2007-2013) under grant agreement n°269179 (Project acronym: COOPLAB)

2 OMF sensor measurement service

NITOS has adopted OMF [3] as its control and management framework. OMF services are groups of specific tasks which operate on the testbed, such as loading a software image into a node or rebooting a set of nodes.

Leveraging on the measurement web service available on the CM cards of NITOS, we implemented a new OMF service called *measure*. It comprises a method for each type of measurement and each of these methods receives two arguments, the HRN of the node (each node features a CM card) and the domain, which is typically the testbed's domain name.

The new service can be utilized by a testbed user directly by invoking it in a browser, or indirectly through an OMF experiment script. In the second case, a user can schedule a measurement related experiment (e.g. monitor some measurement data for a given time interval) or use the measurement as feedback which may drive some kind of on-the-fly steering of a network experiment.

A pre-defined experiment script has been bundled as a new OMF command available at NITOS, called *omf measure*. This command has the following format:

```
omf measure [-s SENSOR-MEASUREMENT] [-h] [-t TOPOLOGY] [-c AGGREGATE]
```

The argument *SENSOR-MEASUREMENT* specifies which measurement is requested from the CM card attached to the nodes in the *TOPOLOGY* argument. If not provided, a list of the available sensors for the specific card(s) is returned.

A scheme of the architecture of the OMF sensor measurement service can be seen in figure 1.

3 Conclusion

We described the implementation of a new OMF service available at the NITOS testbed, which provides measurements from sensors attached to the CM cards of the testbed nodes, upon request.

References

1. NITOS testbed: <http://nitlab.inf.uth.gr/NITlab/index.php/testbed>
2. NITOS CM cards: <http://nitlab.inf.uth.gr/NITlab/index.php/testbed/hardware/cm-card>
3. OMF : A Control and Management Framework for Networking Testbeds, T. Rakotoarivelo, M. Ott, G. Jourjon, and I. Seskar. ACM SIGOPS Operating Systems Review, Vol. 43, pp. 5459, 2010.

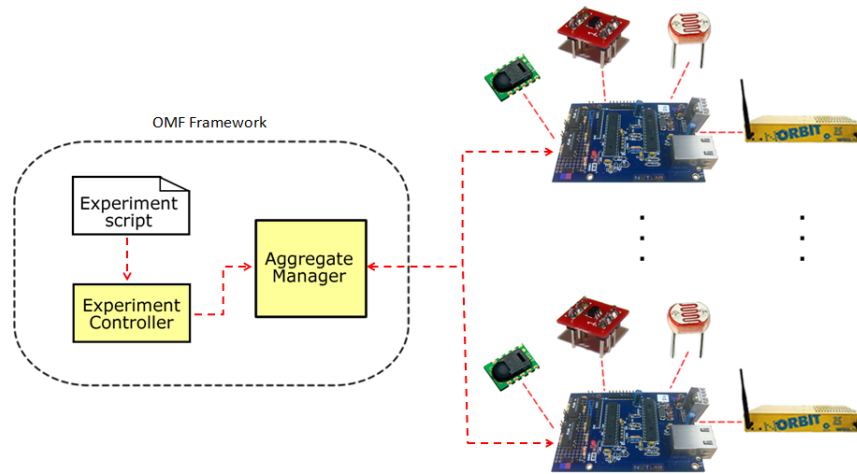

Fig. 1. Provision of measurement OMF service through CM cards